

1. Lope over poles (Right Lead).
2. Break to the jog, jog over poles, jog up to gate.
3. Work gate Left Hand.
4. Walk forward, then lope over poles (Left Lead).
5. Break to the jog, jog through serpentine, jog over poles.
6. Lope over poles (Left Lead).
7. Lope over poles (Left Lead).
8. Break to the jog, jog over poles.
9. Jog over poles, jog into chute.
10. Back between poles, back into box.
11. Execute a 360 turn either way.
12. Walk out box, walk over poles.

Mayflower
IQHA State Show

Thursday
4/30

L1 Trail, L1 Amateur
L1 Youth, Junior Trail

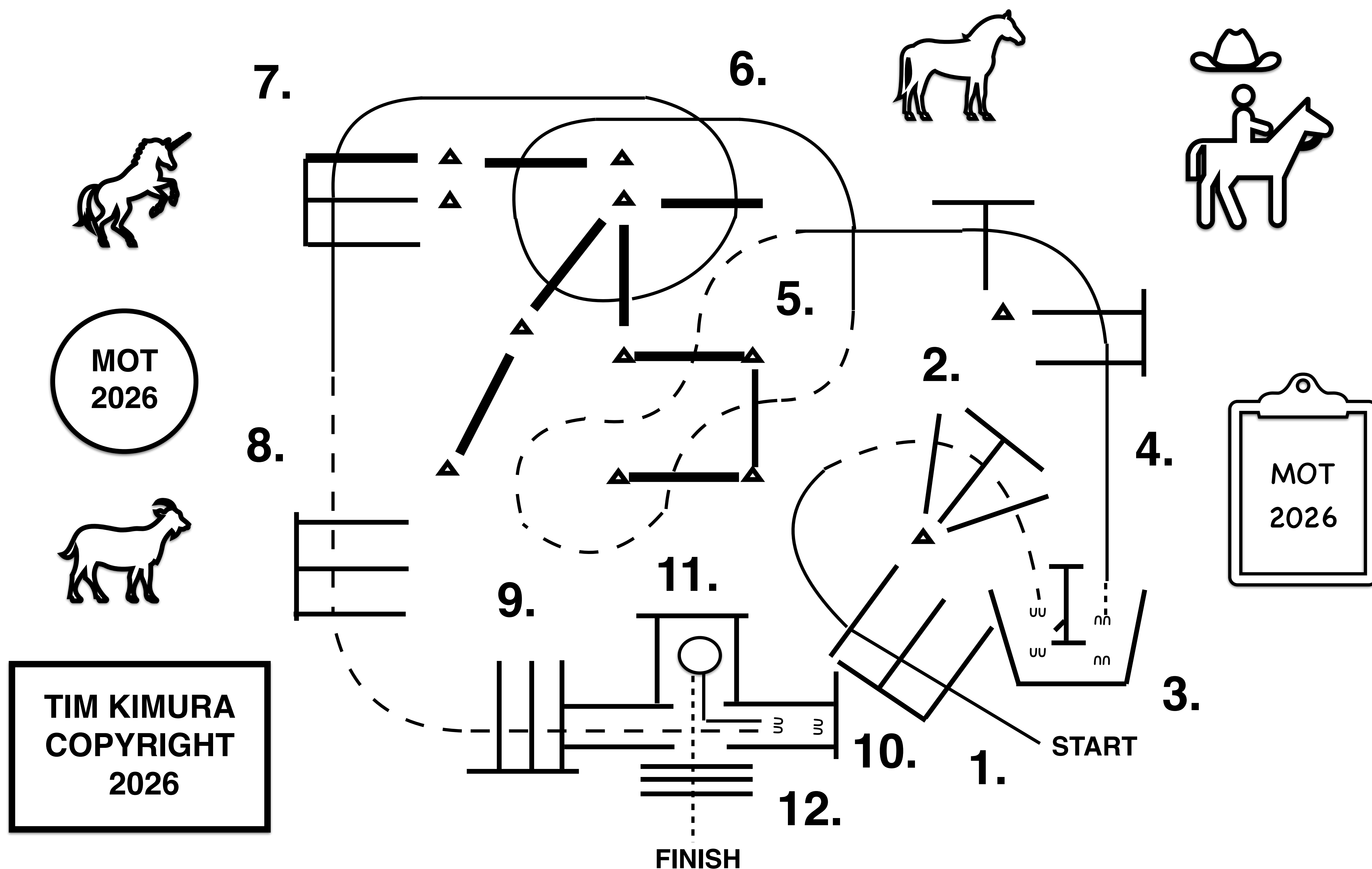

1. Lope over poles (Right Lead).
2. Break to the jog, jog over poles, jog up to gate.
3. Work gate Left Hand.
4. Walk forward, then lope over poles (Left Lead).
5. Break to the jog, jog through serpentine, jog over poles.
6. Lope over poles (Left Lead).
7. Lope over poles (Left Lead).
8. Break to the jog, jog over poles.
9. Jog over poles, jog into chute.
10. Back between poles, back into box.
11. Execute a 360 turn either way.
12. Walk out box, walk over poles.

Mayflower
IQHA State Show

Thursday
4/30

L1 Amateur WT Trail
L1 Youth WT Trail
IQHA Youth 9 & Under

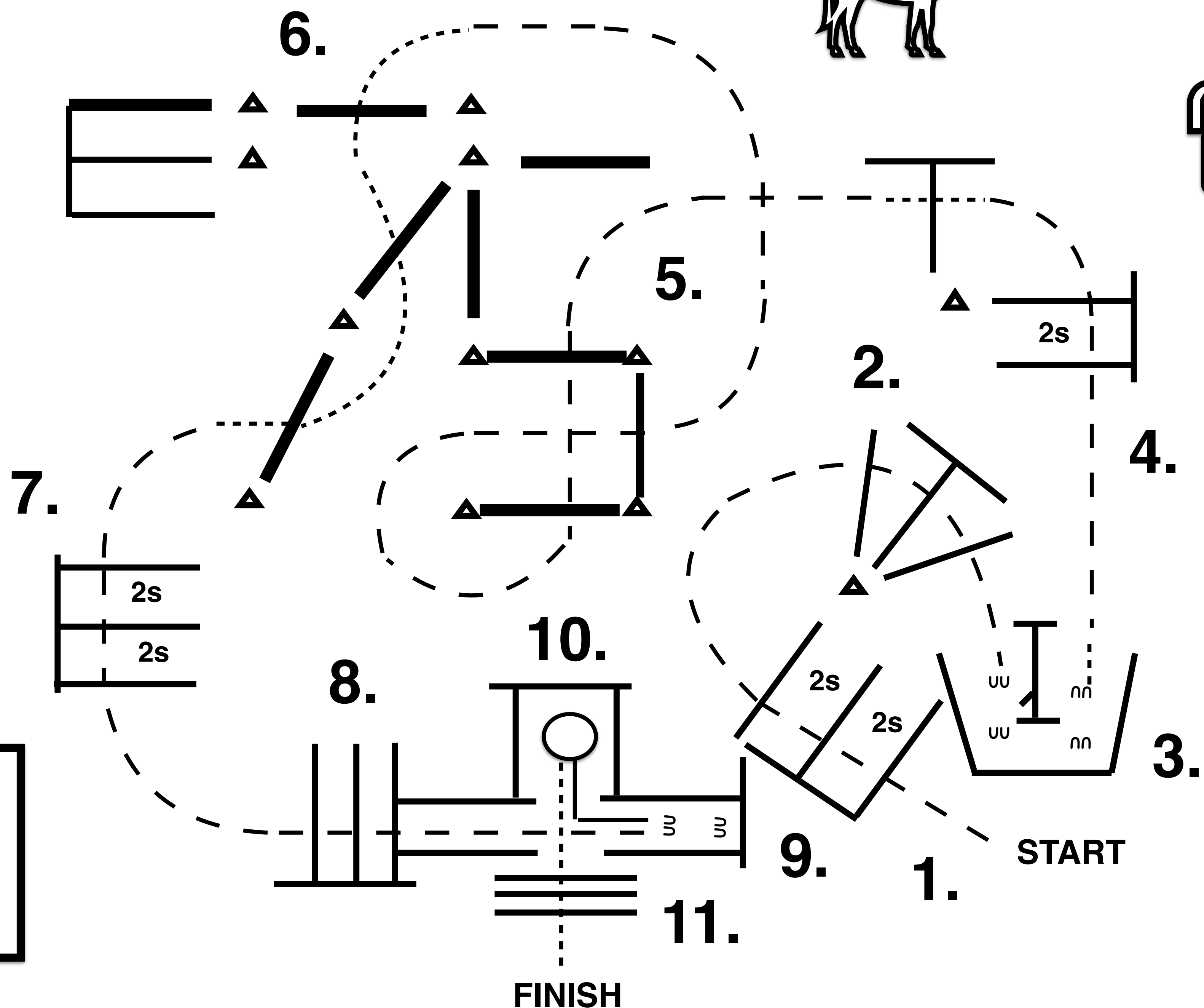
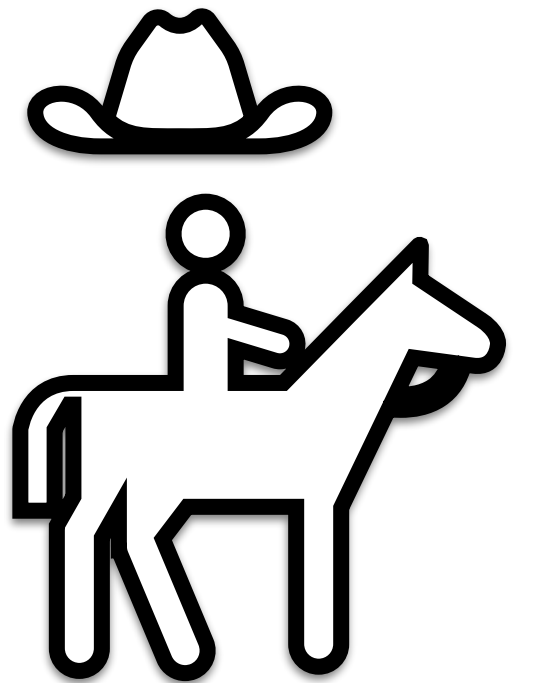
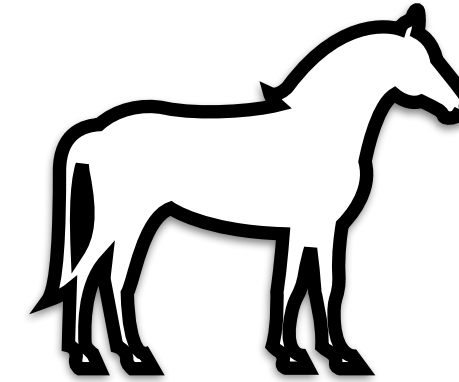
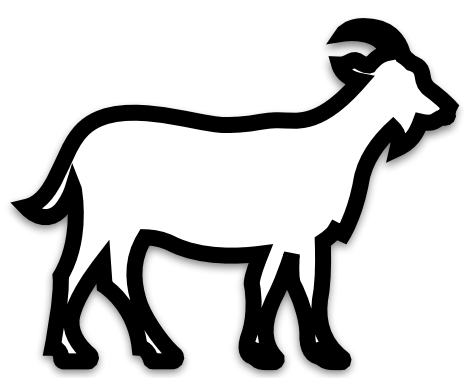
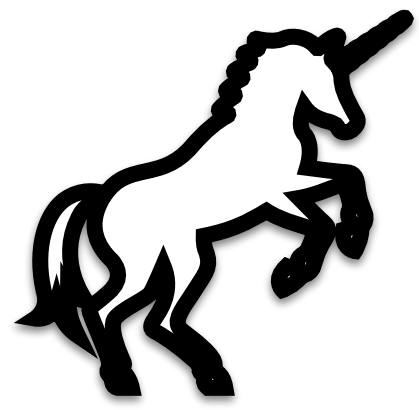

TIM KIMURA
COPYRIGHT
2026

1. Jog over poles.
2. Jog over poles, jog up to gate.
3. Work gate Left Hand.
4. Walk forward, then jog over 2 poles, then walk over 1 pole.
5. Jog through serpentine, jog over poles.
6. Stop or break to the walk, walk through serpentine.
7. Jog over poles.
8. Jog over poles, jog into chute.
9. Back between poles, back into box.
10. Execute a 360 turn either way.
11. Walk out box, walk over poles.

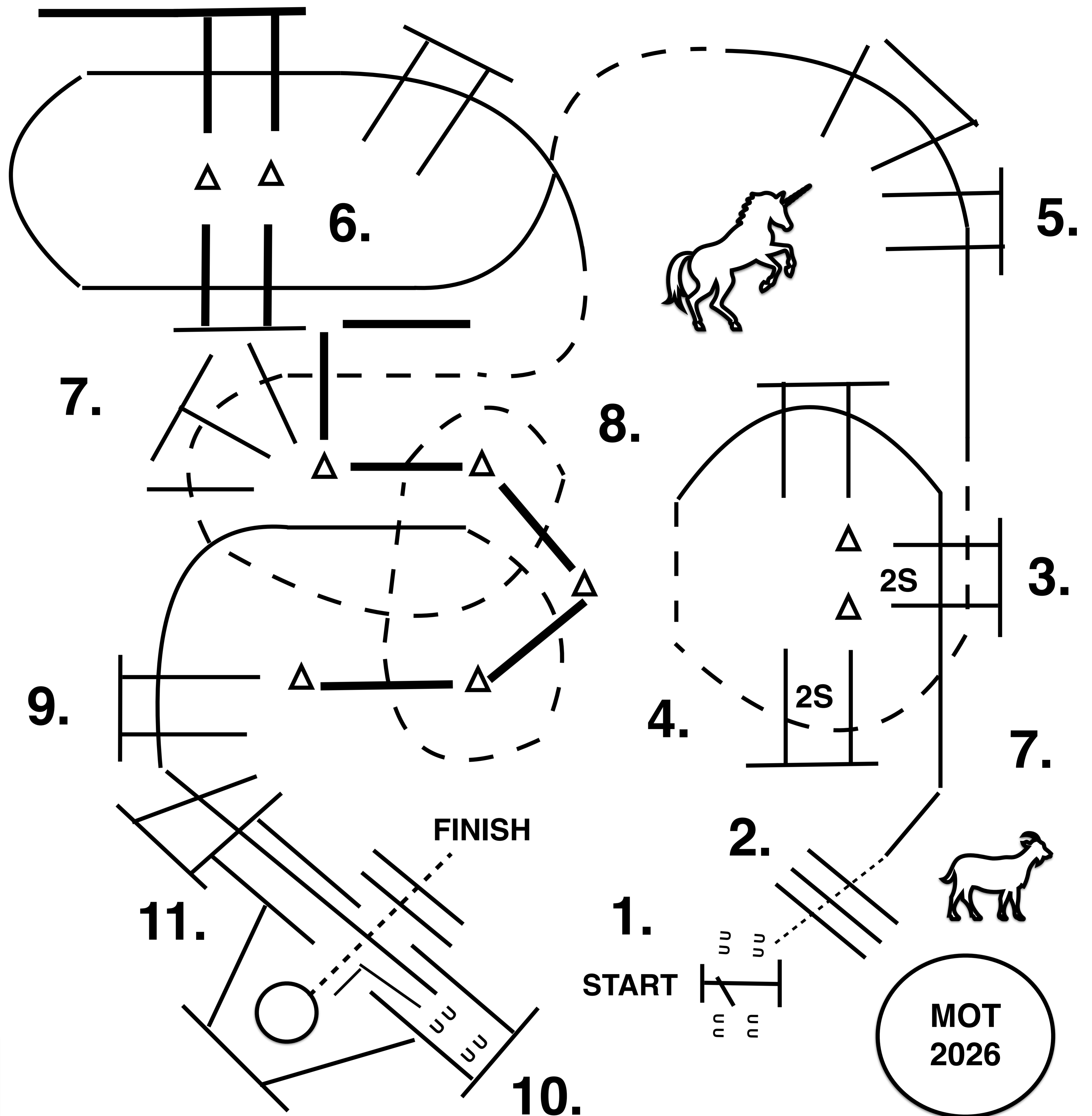
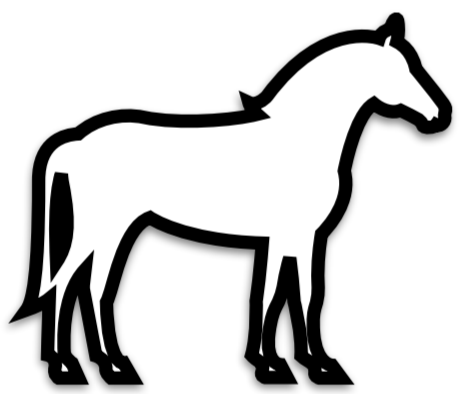
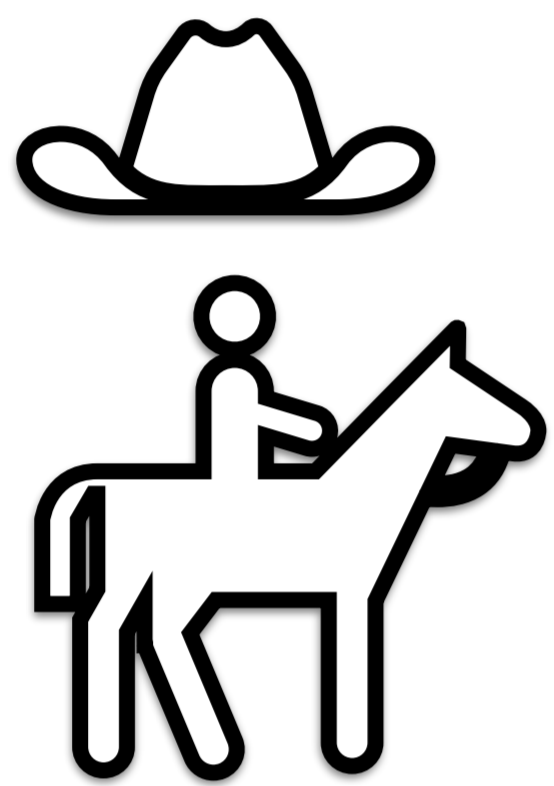
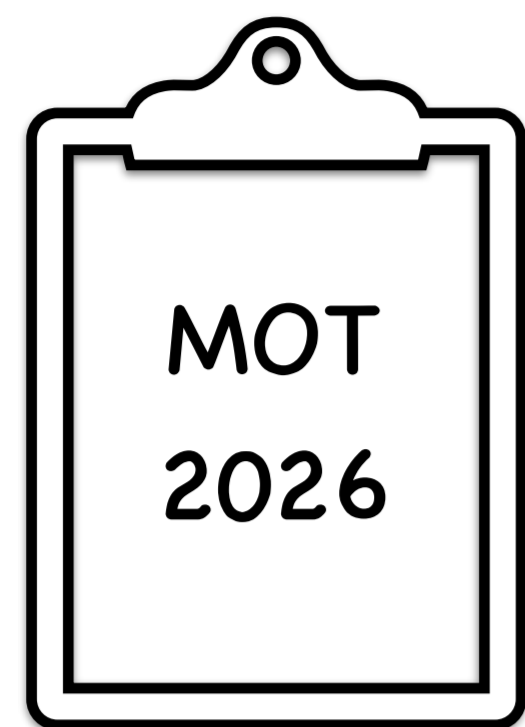

TIM KIMURA
COPYRIGHT
2026

1. Work gate, Right Hand.
2. Walk over poles.
3. Lope over poles (Left Lead).
4. Break to the jog, jog over poles.
5. Lope over poles (Left Lead).
6. Break to the jog, then Lope over poles (Right Lead).
7. Break to the jog, jog over poles.
8. Jog through serpentine, jog over poles.
9. Lope over poles (Left Lead), Lope into chute and stop.
10. Back between poles, back into chute.
11. Execute a 360 turn either way, Walk out over poles.

Mayflower
IQHA State Show

Sunday
5/3

L1 Trail, L1 Amateur
L1 Youth, Junior Trail

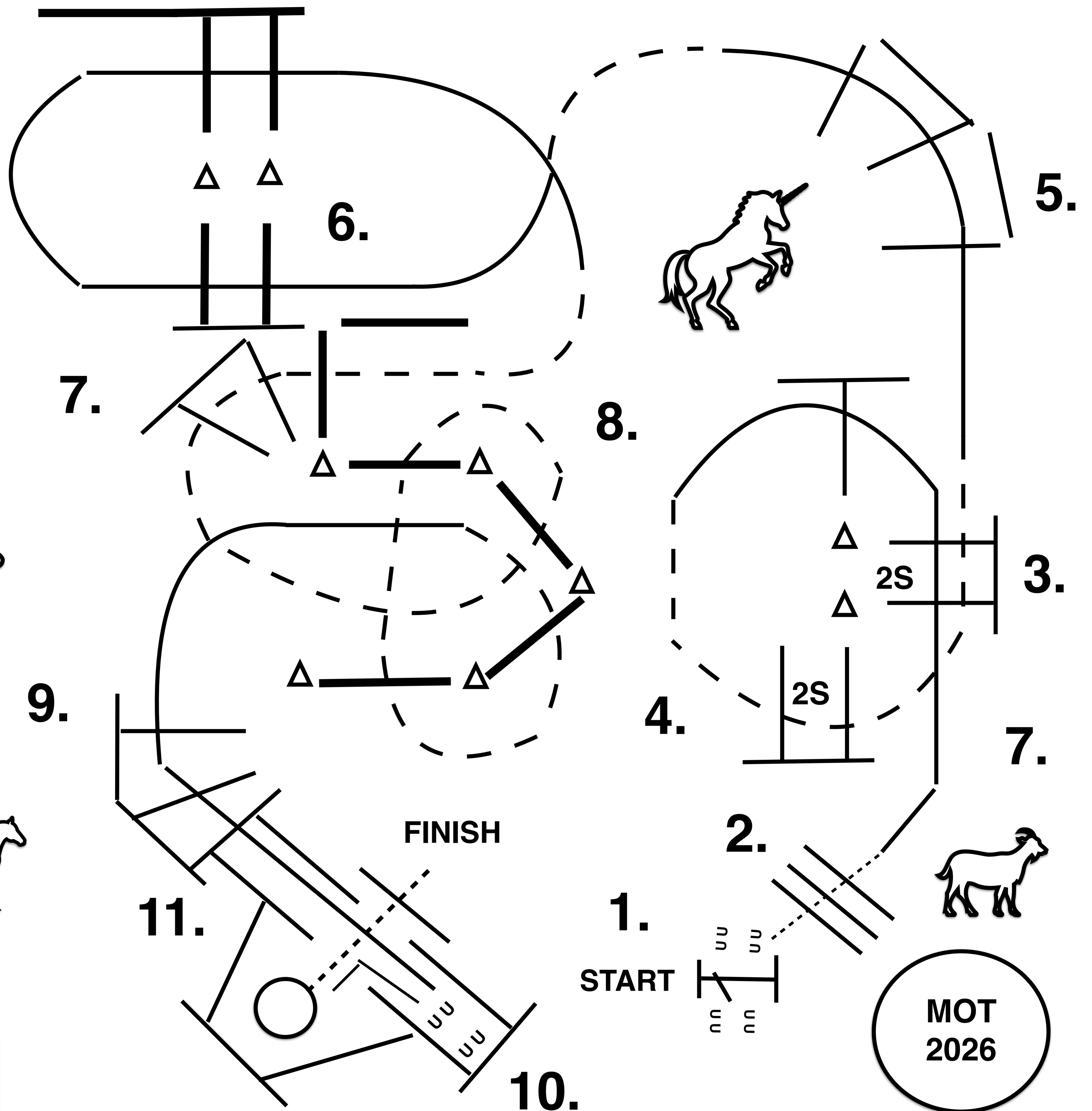
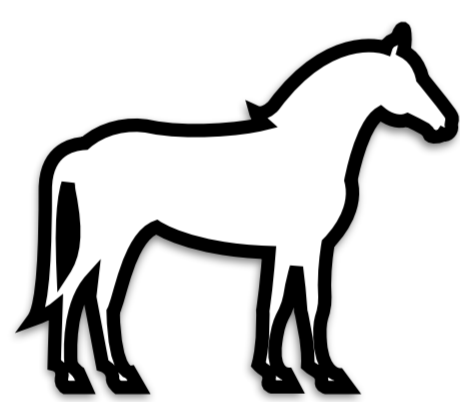
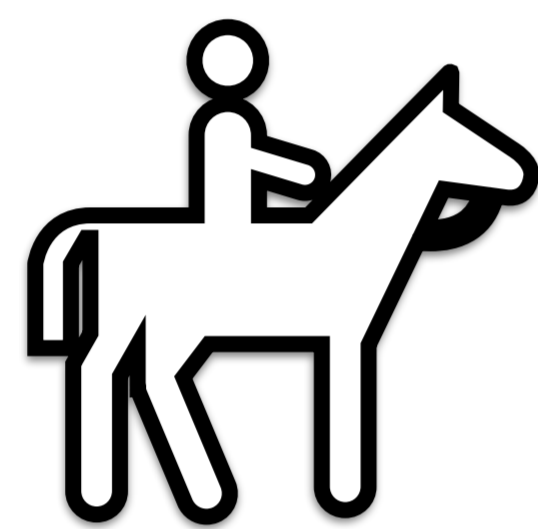
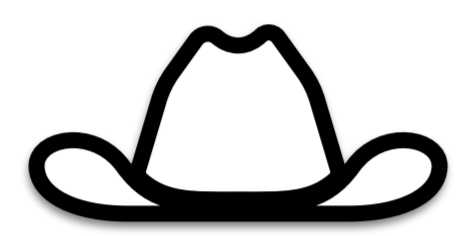
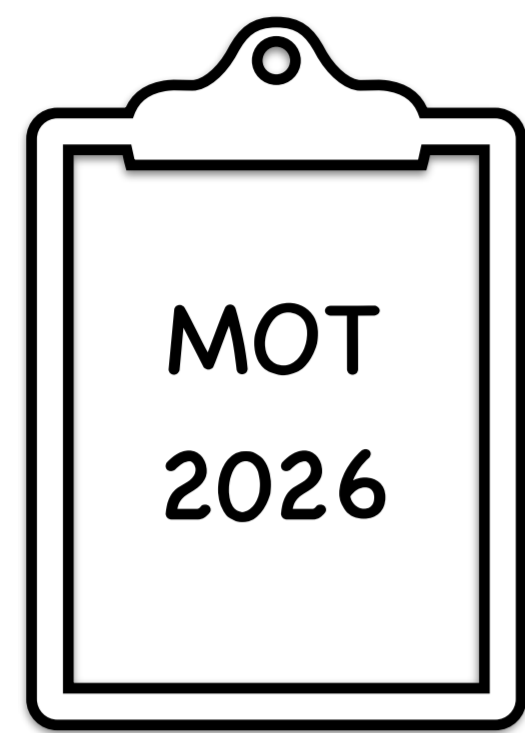

TIM KIMURA
COPYRIGHT
2026

1. Work gate, Right Hand.
2. Walk over poles.
3. Lope over poles (Left Lead).
4. Break to the jog, jog over poles.
5. Lope over poles (Left Lead).
6. Break to the jog, then Lope over poles (Right Lead).
7. Break to the jog, jog over poles.
8. Jog through serpentine, jog over poles.
9. Lope over poles (Left Lead), Lope into chute and stop.
10. Back between poles, back into chute.
11. Execute a 360 turn either way, Walk out over pole.

Mayflower
 IQHA State Show

Sunday
 5/3

L1 Amateur WT Trail
 L1 Youth WT Trail
 IQHA Youth 9 & Under

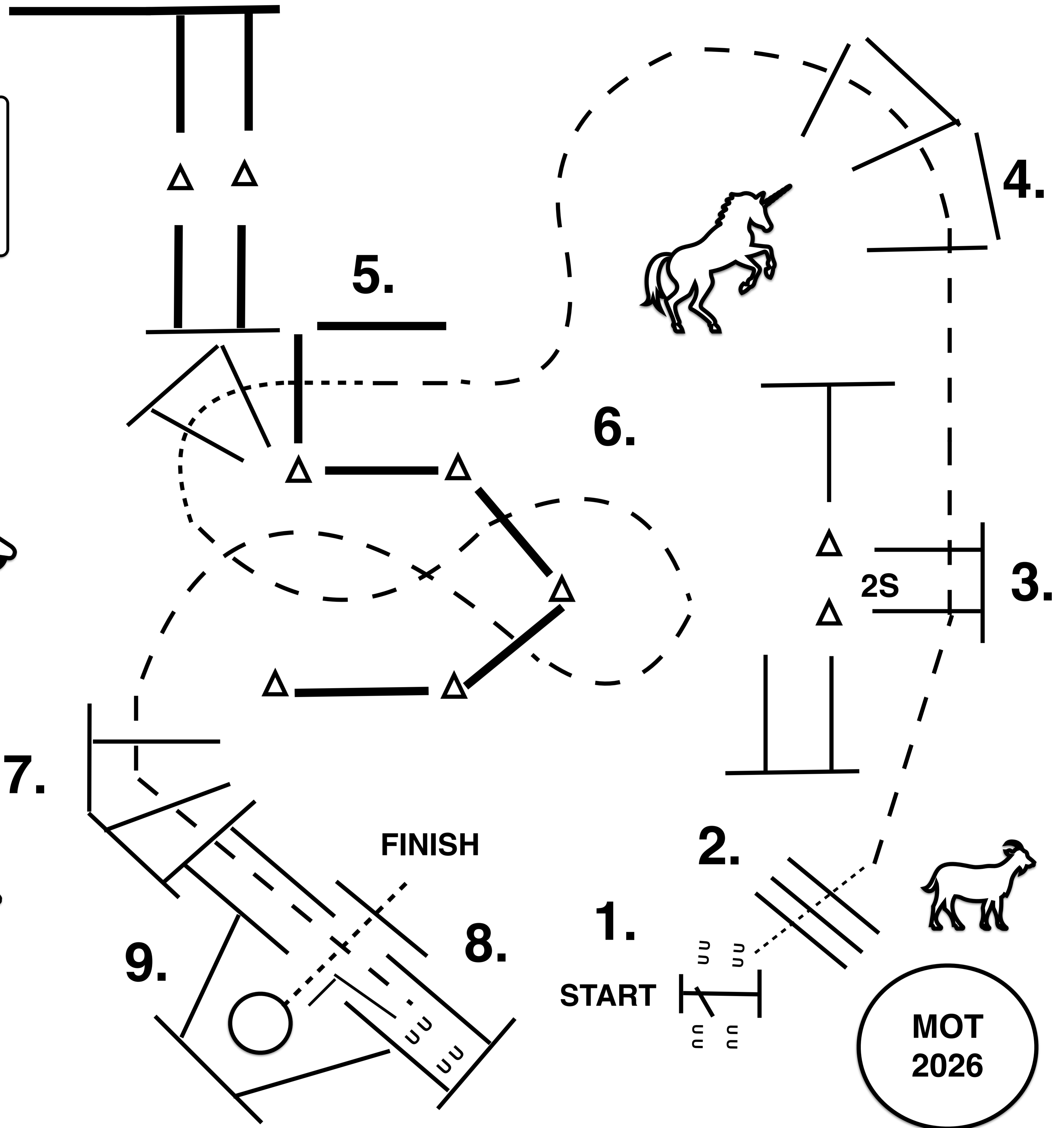
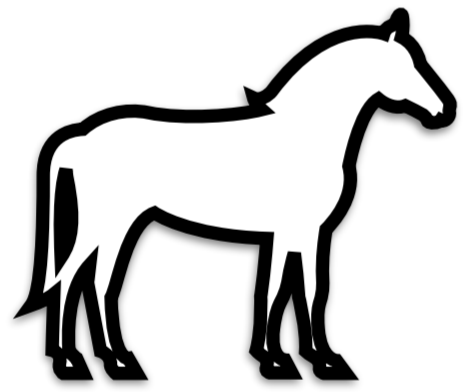
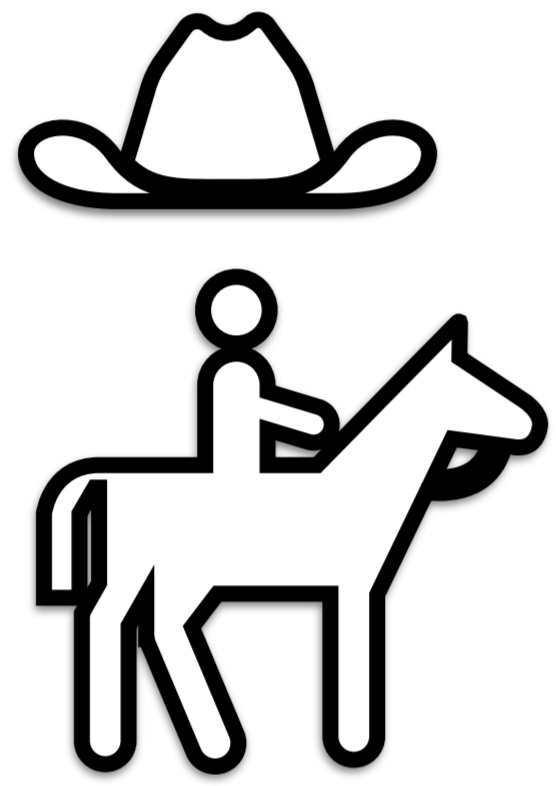
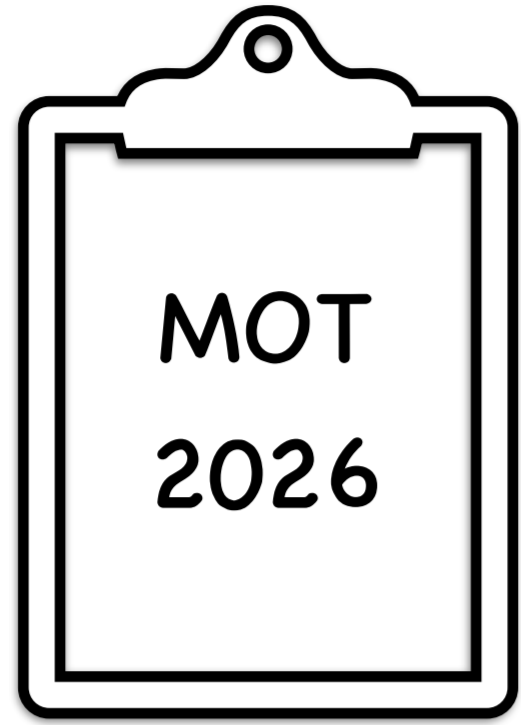

TIM KIMURA
 COPYRIGHT
 2026

1. Work gate, Right Hand.
2. Walk over poles.
3. Jog over poles.
4. Jog over poles.
5. Stop or break to the walk, walk over poles.
6. Jog through serpentine, jog over poles.
7. Jog over poles, jog into chute and stop.
8. Back between poles, back into chute.
9. Execute a 360 turn either way, Walk out over pole.